

PROPRIETARY
THIS DOCUMENT CONTAINS CONFIDENTIAL, PROPRIETARY INFORMATION THAT IS FOX PROPERTY. DO NOT DISCLOSE TO OR DUPLICATE FOR OTHERS EXCEPT AS AUTHORIZED BY FOX.

018-01-004-A
Fastener, Standard: Screw [#8-32 X 0.250 TLG] 303 SS, Socket Set Half Dog Point

TORQUE:
5.0±0.5 IN-LBF

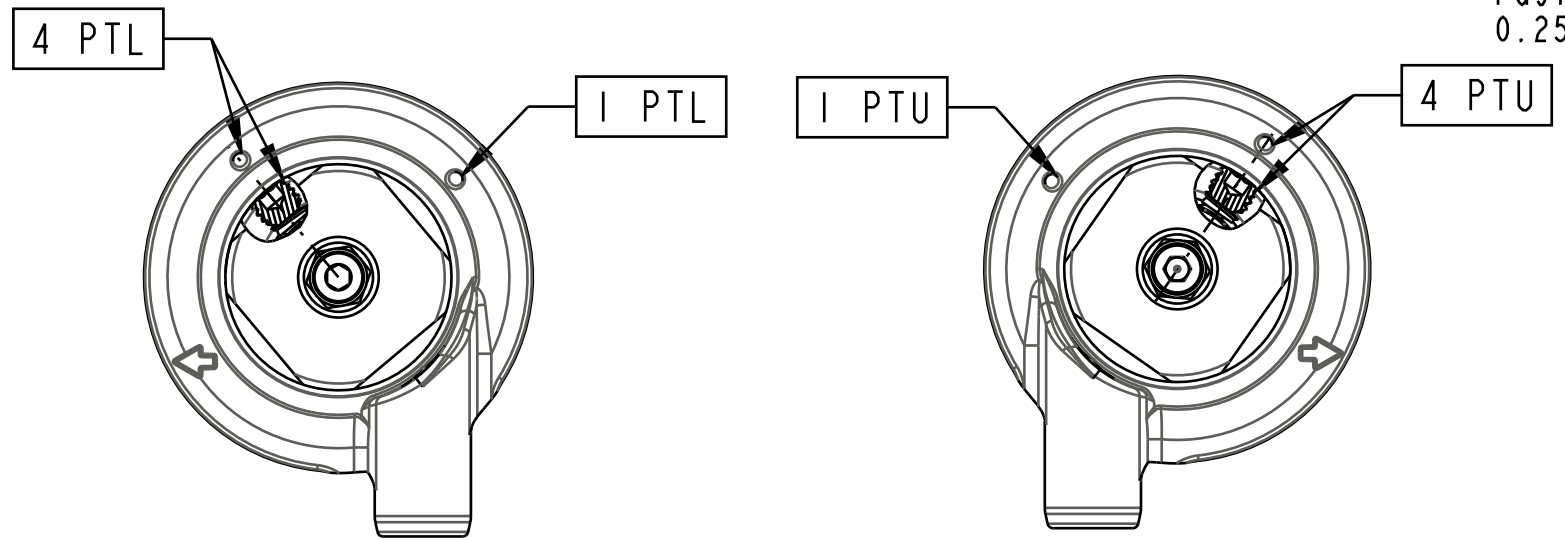

PUSH-TO-LOCK
SECTION C-C

PUSH-TO-UNLOCK
SECTION C-C
SCALE 3:2

IMPORTANT:
NOTE SEAL ORIENTATION

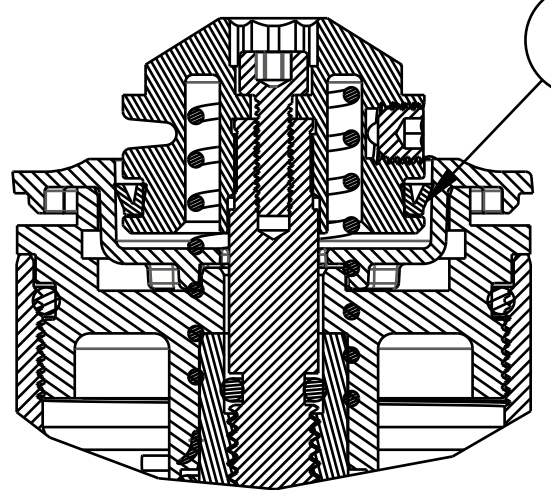

SECTION A-A
SCALE 2:1

820-03-636-KIT
2020 Marzocchi Z2 34 E-Bike+ RAIL 100-150 Damper Shaft Assy Complete

820-05-643-KIT
2020 Marzocchi Z2 34 E-Bike+ RAIL
Remote Topcap Comp Assy, Black Ano

TOPCAP INTERFACE PARTS INSTALL NOTES:

- PUSH-TO-LOCK (PTL) INSTRUCTIONS:**
- 1 PTL SUB-ASSEMBLE TOPCAP INTERFACE PARTS WITH PULLEY SET SCREW FACING THE DOT OPPOSITE THE ARROW.
 2. INSTALL 1 PTL SUB-ASSY TO DAMPER WITH ARROW FACING DESIRED DIRECTION FOR CABLE ROUTING. TIGHTEN 019-01-148 2-3 TURNS (DO NOT RUN DOWN).
 3. ROTATE ONLY THE CABLE HOUSING 250° CCW (ONE 20° INDEX NOTCH POSITION LESS THAN 3/4 TURN) AFTER INSTALLING. CHECK CABLE DIRECTION. TORQUE 019-01-148 WHILE HOLDING PULLEY.
- 4 PTL WHEN LOCKED OUT (ADD 5-6 IN-LB CW TORQUE TO PULLEY), SET SCREW MUST BE ALIGNED TO MARK ±20°.
5. PULLEY MUST RETURN FREELY AFTER LOCKOUT (FROM FORCE OF TORSION SPRING ALONE).
- PUSH-TO-UNLOCK (PTU) INSTRUCTIONS:**
- 1 PTU SUB-ASSEMBLE TOPCAP INTERFACE PARTS WITH PULLEY SET SCREW FACING THE DOT OPPOSITE THE ARROW.
 2. INSTALL 1 PTU PARTS SUB-ASSY TO DAMPER WITH ARROW FACING DESIRED DIRECTION FOR CABLE ROUTING. TIGHTEN 019-01-148 4-5 TURNS (DO NOT RUN DOWN).
 3. ROTATE ONLY THE CABLE HOUSING 250° CW (ONE 20° INDEX NOTCH POSITION LESS THAN 3/4 TURN) TO PRELOAD TORSION SPRING. CHECK CABLE DIRECTION.
- 4 PTU WHEN LOCKED OUT (STEP 3 COMPLETE, NO EXTRA TORQUE ADDED TO PULLEY), CHECK THAT SET SCREW IS ALIGNED TO MARK ±20°. TORQUE 019-01-148 WHILE HOLDING PULLEY.
5. PULLEY MUST RETURN FREELY AFTER UNLOCK (FROM FORCE OF TORSION SPRING ALONE).

TORQUE:
PUSH-TO-LOCK & PUSH-TO-UNLOCK:
TORQUE NEEDLE TO 8.0±0.8 OZF-IN BEFORE
INSTALLING TOPCAP INTERFACE PARTS
(SAME TORQUE FOR CARTRIDGE DYNO)

GREASE:
THIN LAYER BLUE MARINE
GREASE ON ID AND OD

TORQUE:
(10±1 IN-LBF)
REF: FOR BIKE INSTALL

TORQUE:
220±5 IN-LBF

REFERENCE ONLY
(FOR INSTALLATION
INTO FORK)

Fastener: Custom
(Metric): Set
Screw [M4 x
.7mm x 3mm]
SST, Patchlock

Housing, Remote, Hubless, GRIP PTU or PTL
TOPCAP INTERFACE PARTS:
820-05-616-KIT: 2020 Marzocchi Z2 34 Rail PTU Remote, Topcap Interface Parts
820-05-617-KIT: 2020 Marzocchi Z2 34 Rail PTL Remote, Topcap Interface Parts

Spring: Torsion, Remote, 2020 GRIP PTU or PTL

Seals: U-Cup, Shore 70A, 2013 CTD-ADJ, Remote Fit-CTD and Remote O/C-CTD

Cable Pulley Remote, 2020 RAIL

TORQUE:
6±1 IN-LBF

Fastener Standard (Metric): Screw [M2.5 X 8mm] Socket Head Cap, SS

marzocchi
A FOX BRAND

2020 Marzocchi Z2 34 E-Bike+ RAIL Remote
100-150 Travel Cart Assys Complete

SIZE C	PART NO.
PLOT SCALE: 1:1	
SHEET 1 OF 1	